

RER

HORIZONTAL DEHUMIDIFIERS WITH HEAT RECOVERY FOR RADIANT SYSTEMS



RER 020

HEAT RECOVERY

VARIABLE SPEED

FREE COOLING

LOW NOISE

DEHUMIDIFICATION

COOLING

HEATING

ISOTHERMIC

AIR FILTERS

R-513a
OZONE FRIENDLY

R-410a
OZONE FRIENDLY

RS485
PROTOCOL
CONNECTION LINK

The **RER** range dehumidifiers with high-efficiency heat recovery system are used in radiant cooling buildings together with an air renewal system. The RER dehumidifiers dehumidify, cool, heat and change the air. They recover heat from expelled air. High pressure and minimum electric consumptions are guaranteed by the adjustable electronic fans with permanent magnet brushless motor and cutting-edge incorporated inverter.

The top-quality refrigeration, hydraulic, aeraulic and electrical components make RER units state of the art dehumidifiers in terms of efficiency, reliability and silence. More than 90% yield is guaranteed by the high-efficiency counter-current heat recovery system. The modulating air renewal can be manual or automatic. The humidifier autonomously controls room temperature and humidity through the standard fitted temperature and humidity sensors. The dehumidifier autonomously controls room temperature and humidity through the optional temperature and humidity sensors. The RER dehumidifiers can be connected to a home automation system thanks to the optional RS485 serial port and requested software customization.

R-513a refrigerant gas is used for **RER 015, 020, 035, 050** units.

R-410a refrigerant gas is used for **RER 100** units.

Technical sheet of the range		RER 015			RER 020		
		A	I	W	A	I	W
Dehumidifying capacity	L/Day	16	16	18	24,5	24,5	29
Nominal air flow	m³/h	160	160	160	260	260	260
Fresh air flow	m³/h	0-80	0-80	0-80	0-130	0-130	0-130
Heat recovery efficiency	%	> 90%					
Cooling power	W	Isothermal	800	1170	Isothermal	1300	1920
Sound level	dB(A)	36	36	35	39	39	38
Power supply	V/ph/Hz	230 / 1~ +N / 50					
Dimensions (base x depth x height)	mm	960 x 610 x 245			1125 x 680 x 250		

Technical sheet of the range		RER 035			RER 050			RER 100		
		A	I	W	A	I	W	A	I	W
Dehumidifying capacity	L/Day	34	34	40	48	48	58	100	100	120
Nominal air flow	m³/h	360	360	360	520	520	520	1000	1000	1000
Fresh air flow	m³/h	0-180	0-180	0-180	0-250	0-250	0-250	0-500	0-500	0-500
Heat recovery efficiency	%	> 90%								
Cooling power	W	Isothermal	1790	2650	Isothermal	3230	3650	Isothermal	6800	7700
Sound level	dB(A)	41	41	39	44	44	43	47	47	44
Power supply	V/ph/Hz	230 / 1~ +N / 50								
Dimensions (base x depth x height)	mm	1125 x 680 x 300			1665 x 760 x 375			1500 x 1120 x 450		

All the values refer to the following conditions: Air temperature 26°C, Relative Humidity 65%, Water temperature 15°C W Version: water at 10°C

The RER range consists of 3 versions : A – I - W

A = Neutral air version (isothermal): The letter “A” represents a neutral air isothermal dehumidifier with air condensation, which is supplied as standard with pre and post cooling coils. The outlet air has the same temperature as the inlet air.

I = Cold integration version: The letter “I” represents a dehumidifier that can add cold power to the radiant system. Thanks to the presence of a brazed plate condenser, the “I” models cool the air as a normal air-conditioner, when required. This function is particularly useful, during half seasons, due to the high difference in temperature or when cooking or when gusts arrive. In order to operate, the “I” models must always receive water from the radiant system.

W = Water version: The letter “W” identifies an especially silent chilled water hydronic dehumidifier without compressor. The outlet air is always cooler than the inlet air. The “W” version supplies conditioned air in summer and heating in winter.

Summer functions

- Renewal
- Renewal + dehumidification
- Renewal + dehumidification + cooling
- Cooling
- Dehumidification
- Dehumidification + Cooling
- Free-cooling

- | | |
|---------------------------------------|-------------------------------|
| 1 Fresh air intake | 9 Exhaust fan |
| 2 Exhaust air intake | 10 Heat recovery system |
| 3 Room air intake (for recirculation) | 11 Recirculation damper |
| 4 Exhaust air discharge | 12 Supply air filter |
| 5 Room air supply | 13 Recovery system air filter |
| 6 Heat exchange coil | 14 Outdoor air filter |
| 7 Blower fan | 15 Outdoor air damper |
| 8 Compressor | |

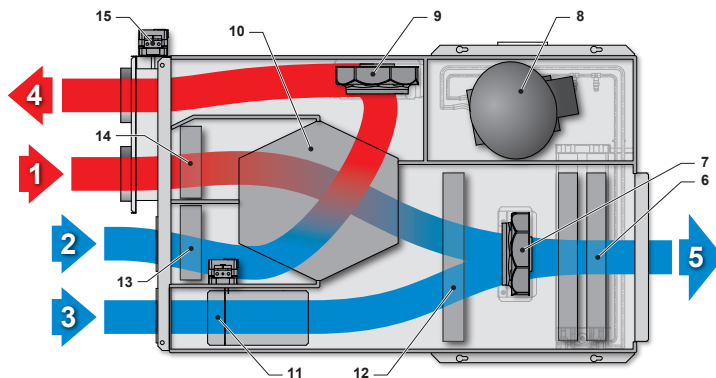

Winter functions

- Renewal
- Renewal + heating
- Heating
- Free-heating

Included:

- Remote on-wall graphic display
- Time bands program
- Multi-speed fresh air
- Electronic radial fans with brushless engine and inverter integrated
- Timed signal for air filters check
- Boost mode for fresh air
- Supply temperature control



Options:

- | | |
|--|---|
| <ul style="list-style-type: none"> - Second display - Outdoor air dampers for dew-point control - Free-cooling - High-efficiency air filter set - Cable for display connection - Additional temperature and humidity probes on board - CO2 probe - VOC probe | <ul style="list-style-type: none"> - Recovery automatic defrost - RS485 serial port - Silent version - Adjustable supply air temperature control - Supply plenum - Recovery plenum - Air distribution: see chapter WMC |
|--|---|